

Endura®

25 XT Grease Interceptor

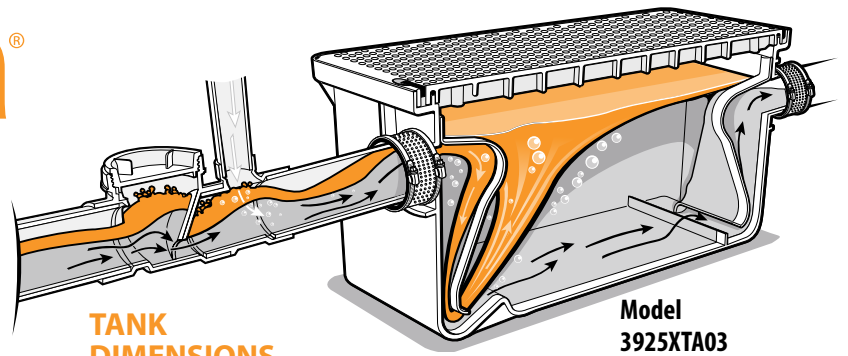

Model
3925XTA03
shown

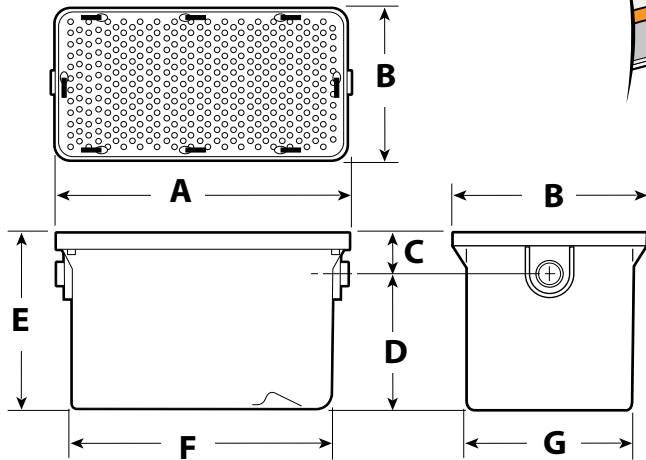

TANK DIMENSIONS

	3925XTA02 (2")	3925XTA03 (3")
A	31.25" (793.75mm)	
B	18.5" (469.9mm)	
C	4" (101.6mm)	4.5" (114.3mm)
D	12.5" (317.5mm)	12" (304.8mm)
E	16.5" (419.1mm)	
F	28" (711.2mm)	
G	15.5" (393.7mm)	



FLOW CONTROL DIMENSIONS

NOM. Pipe Size	1 Piece Compact 2" h x h	2 Piece 2" h x h	2 Piece 3" h x h
A	3.94" (100mm)	3" (76.2mm)	4.23" (107.4mm)
B	3.44" (87.4mm)	3.84" (97.5mm)	5.93" (151mm)
C	-	-	-

AIR INTAKE DIMENSIONS

2" spg x h	3" spg x h
2.91" (73.9mm)	2.67" (67.8mm)
2.71" (68.8mm)	4.01" (101.9mm)
2.24" (56mm)	2.27" (57.7mm)

1 Piece Compact Flow Control (2" Version Illustrated)

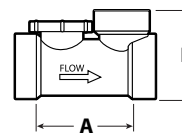

A 2" two piece flow control is also available for purchase.

2 Piece Flow Control (3" Version Illustrated)

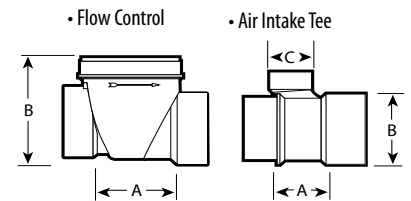

See C39 Pricelist for details

CAPACITIES

DESCRIPTION	Endura 25-02	Endura 25-03
Part Number	3925XTA02 (2")	3925XTA03 (3")
US Gallons Per Minute - GPM (L/Sec)	25 (1.6)	25 (1.6)
Min. Grease Capacity - lb (kg) ▲	50 (22.68)	50 (22.68)
Grease Capacity Actual - lb (kg) ■	72.55 (32.90)	73.01 (33.11)
Average Efficiency % (ASME A112.14.3) *	96.7%	97.3%
Operating Temperature Capabilities	220°F (104°C)	220°F (104°C)
Cover Load Rating- CSA B481.0 (Proof Load for Approval)	L 440 lb (200 kg)	L 440 lb (200 kg)
Unit Weight (Empty) - lb (kg)	35.61 (16.153)	37.77 (17.136)
Liquid Capacity - gal. (L)	30.6 (115.83)	29.5 (111.67)
Connection size (mechanical joint only)	2"	3"

SAMPLE SPECIFICATION

Contractor shall install Endura 25XT Grease Interceptor, Part Number: 3925XTA02 3925XTA03 – (mark as applicable) supplied with operationally accessible external flow control device and installed per manufacturer's instructions. The interceptor tank shall be of single piece injection molded thermoplastic construction, capable of withstanding constant discharge temperatures up to 212°F (104°C). The interceptor shall incorporate a CSA B481.0 approved cover with cam-latch access system and be capable of supporting 440lb (220kg). Endura modular riser extensions part number 3925AX6 - Enter Quantity: _____, are not required for this installation – refer to manufacturers installation instructions. The interceptor shall be tested and approved to the current version of PDI-G101, ASME A112.14.3 and CSA B481 and manufacturer will provide option for extended warranty for a period of 10 years from date of installation. Contractor to provide locally approved mechanical joint couplings for connection of adjacent piping system to the grease interceptor.

ARCAT.com



Tel: (705) 726-3361

Toll Free: 1-800-461-5300

Fax: (705) 726-2186

Canplas Industries Ltd.
Separation Technologies Group
500 Veterans Drive, PO Box 1800
Barrie, ON L4M 4V3 Canada

Email: tech-support@endurainterceptor.com

canplas

an OAliaxis company

* CSA B481.1

▲ **Grease Capacity Min - lb (kg):** Industry minimum grease capacity based on GPM flow rate. Requires minimum 2 lb of grease capacity for each GPM of flow.

■ **Grease Capacity Actual - lb (kg):** Actual capacity at breakdown when tested to ASME A112.14.3

